

Technician Class Question Pool – July 2010

T1A01 (D) [97.3(a)(4)]

For whom is the Amateur Radio Service intended?

- A. Persons who have messages to broadcast to the public
- B. Persons who need communications for the activities of their immediate family members, relatives and friends
- C. Persons who need two-way communications for personal reasons
- D. Persons who are interested in radio technique solely with a personal aim and without pecuniary interest

T1A02 (C) [97.1]

What agency regulates and enforces the rules for the Amateur Radio Service in the United States?

- A. FEMA
- B. The ITU
- C. The FCC
- D. Homeland Security

T1A03 (D)

Which part of the FCC rules contains the rules and regulations governing the Amateur Radio Service?

- A. Part 73
- B. Part 95
- C. Part 90
- D. Part 97

T1A04 (C) [97.3(a)(23)]

Which of the following meets the FCC definition of harmful interference?

- A. Radio transmissions that annoy users of a repeater
- B. Unwanted radio transmissions that cause costly harm to radio station apparatus
- C. That which seriously degrades, obstructs, or repeatedly interrupts a radio communication service operating in accordance with the Radio Regulations
- D. Static from lightning storms

T1A05 (D) [97.3(a)(40)]

What is the FCC part 97 definition of a space station?

- A. Any multi stage satellite

- B. An Earth satellite that carries one of more amateur operators

- C. An amateur station located less than 25 km above the Earth's surface

- D. An amateur station located more than 50 km above the Earth's surface

T1A06 (C) [97.3(a)(43)]

What is the FCC part 97 definition of telecommand?

- A. An instruction bulletin issued by the FCC

- B. A one-way radio transmission of measurements at a distance from the measuring instrument

- C. A one-way transmission to initiate, modify or terminate functions of a device at a distance

- D. An instruction from a VEC

T1A07 (C) [97.3(a)(45)]

What is the FCC part 97 definition of telemetry?

- A. An information bulletin issued by the FCC

- B. A one-way transmission to initiate, modify or terminate functions of a device at a distance

- C. A one-way transmission of measurements at a distance from the measuring instrument

- D. An information bulletin from a VEC

T1A08 (B) [97.3(a)(22)]

Which of the following entities recommends transmit/receive channels and other parameters for auxiliary and repeater stations?

- A. Frequency Spectrum Manager

- B. Frequency Coordinator

- C. Regional Field Office

- D. International Telecommunications Union

T1A09 (C) [97.3(a)(22)]

Who selects a frequency coordinator?

- A. The FCC Office of Spectrum Management and Coordination Policy

- B. The local chapter of the Office of National Council of Independent Frequency Coordinators

- C. Amateur operators in a local or regional area that are eligible to be auxiliary or repeater stations

- D. Regional field Office

T1A10 (A) [97.3(a)(5)]

What is the FCC part 97 definition of an amateur station?

- A. A station in an Amateur Radio Service consisting of the apparatus necessary for carrying on radio communications
- B. A building where Amateur Radio receivers, transmitters, and RF power amplifiers are installed
- C. Any radio station operated by a non-professional
- D. Any radio station for hobby use

T1A11 (C) [97.3(a)(7)]

Which of the following stations transmits signals over the air from a remote receive site to a repeater for retransmission?

- A. Beacon station
- B. Relay station
- C. Auxiliary station
- D. Message forwarding station

T1B01 (B) [97.3(a)(2)]

What is the ITU?

- A. An agency of the United States Department of Telecommunications Management
- B. A United Nations agency for information and communication technology issues
- C. An independent frequency coordination agency
- D. A department of the FCC

T1B02 (B)

North American amateur stations are located in which ITU region?

- A. Region 1
- B. Region 2
- C. Region 3
- D. Region 4

T1B03 (B) [97.301(a)]

Which frequency is within the 6 meter band?

- A. 49.00 MHz
- B. 52.525 MHz
- C. 28.50 MHz
- D. 222.15 MHz

T1B04 (A) [97.301(a)]

Which amateur band are you using when your station is transmitting on 146.52 MHz?

- A. 2 meter band

- B. 20 meter band
- C. 14 meter band
- D. 6 meter band

T1B05 (C) [97.301(a)]

Which 70 cm frequency is authorized to a Technician Class license holder operating in ITU Region 2?

- A. 53.350 MHz
- B. 146.520 MHz
- C. 443.350 MHz
- D. 222.520 MHz

T1B06 (B) [97.301(a)]

Which 23 cm frequency is authorized to a Technician Class operator license?

- A. 2315 MHz
- B. 1296 MHz
- C. 3390 MHz
- D. 146.52 MHz

T1B07 (D) [97.301(a)]

What amateur band are you using if you are transmitting on 223.50 MHz?

- A. 15 meter band
- B. 10 meter band
- C. 2 meter band
- D. 1.25 meter band

T1B08 (C) [97.303]

What do the FCC rules mean when an amateur frequency band is said to be available on a secondary basis?

- A. Secondary users of a frequency have equal rights to operate
- B. Amateurs are only allowed to use the frequency at night
- C. Amateurs may not cause harmful interference to primary users
- D. Secondary users are not allowed on amateur bands

T1B09 (D) [97.101(a)]

Why should you not set your transmit frequency to be exactly at the edge of an amateur band or sub-band?

- A. To allow for calibration error in the transmitter frequency display
- B. So that modulation sidebands do not extend beyond the band edge

- C. To allow for transmitter frequency drift
- D. All of these choices are correct

T1B10 (C) [97.305(c)]

Which of the bands available to Technician Class operators have mode-restricted sub-bands?

- A. The 6 meter, 2 meter, and 70 cm bands
- B. The 2 meter and 13 cm bands
- C. The 6 meter, 2 meter, and 1.25 meter bands
- D. The 2 meter and 70 cm bands

T1B11 (A) [97.305 (a)(c)]

What emission modes are permitted in the mode-restricted sub-bands at 50.0 to 50.1 MHz and 144.0 to 144.1 MHz?

- A. CW only
- B. CW and RTTY
- C. SSB only
- D. CW and SSB

T1C01 (C) [97.3(a)(11)(iii)]

Which type of call sign has a single letter in both the prefix and suffix?

- A. Vanity
- B. Sequential
- C. Special event
- D. In-memoriam

T1C02 (B)

Which of the following is a valid US amateur radio station call sign?

- A. KMA3505
- B. W3ABC
- C. KDKA
- D. 11Q1176

T1C03 (A) [97.117]

What types of international communications are permitted by an FCC-licensed amateur station?

- A. Communications incidental to the purposes of the amateur service and to remarks of a personal character
- B. Communications incidental to conducting business or remarks of a personal nature
- C. Only communications incidental to contest exchanges, all other communications are prohibited
- D. Any communications that would be permitted on an international broadcast station

T1C04 (A)

When are you allowed to operate your amateur station in a foreign country?

- A. When the foreign country authorizes it
- B. When there is a mutual agreement allowing third party communications
- C. When authorization permits amateur communications in a foreign language
- D. When you are communicating with non-licensed individuals in another country

T1C05 (A) [97.303(h)]

What must you do if you are operating on the 23 cm band and learn that you are interfering with a radiolocation station outside the United States?

- A. Stop operating or take steps to eliminate the harmful interference
- B. Nothing, because this band is allocated exclusively to the amateur service
- C. Establish contact with the radiolocation station and ask them to change frequency
- D. Change to CW mode, because this would not likely cause interference

T1C06 (D) [97.5(a)(2)]

From which of the following may an FCC-licensed amateur station transmit, in addition to places where the FCC regulates communications?

- A. From within any country that belongs to the International Telecommunications Union
- B. From within any country that is a member of the United Nations
- C. From anywhere within in ITU Regions 2 and 3
- D. From any vessel or craft that is documented or registered in the United States

T1C07 (B) [97.23]

What may result when correspondence from the FCC is returned as undeliverable because the grantee failed to provide the correct mailing address?

- A. Fine or imprisonment
- B. Revocation of the station license or suspension of the operator license
- C. Require the licensee to be re-examined
- D. A reduction of one rank in operator class

T1C08 (C) [97.25]

What is the normal term for an FCC-issued primary station/operator license grant?

- A. Five years
- B. Life
- C. Ten years
- D. Twenty years

T1C09 (A) [97.21(a)(b)]

What is the grace period following the expiration of an amateur license within which the license may be renewed?

- A. Two years
- B. Three years
- C. Five years
- D. Ten years

T1C10 (C) [97.5a]

How soon may you transmit after you pass the examination elements required for your first amateur radio license?

- A. Immediately
- B. 30 days after the test date
- C. As soon as your name and call sign appear in the FCC's ULS database
- D. As soon as you receive your license from the FCC

T1C11 (A) [97.21(b)]

If your license has expired and is still within the allowable grace period, may you continue to transmit?

- A. No, transmitting is not allowed until the ULS database shows that the license has been renewed
- B. Yes, but only if you identify using the suffix "GP"
- C. Yes, but only during authorized nets
- D. Yes, for up to two years

T1D01 (A) [97.111(a)(1)]

With which countries are FCC-licensed amateur stations prohibited from exchanging communications?

- A. Any country whose administration has notified the ITU that it objects to such communications
- B. Any country whose administration has notified the United Nations that it objects to such communications
- C. Any country engaged in hostilities with another country

D. Any country in violation of the War Powers Act of 1934

T1D02 (A) [97.111(a)(5)]

On which of the following occasions may an FCC-licensed amateur station exchange messages with a U.S. military station?

- A. During an Armed Forces Day Communications Test
- B. During a Memorial Day Celebration
- C. During an Independence Day celebration
- D. During a propagation test

T1D03 (C) [97.113(a)(4), 97.211(b), 97.217]

When is the transmission of codes or ciphers allowed to hide the meaning of a message transmitted by an amateur station?

- A. Only during contests
- B. Only when operating mobile
- C. Only when transmitting control commands to space stations or radio control craft
- D. Only when frequencies above 1280 MHz are used

T1D04 (A) [97.113(a)(4), 97.113(e)]

What is the only time an amateur station is authorized to transmit music?

- A. When incidental to an authorized retransmission of manned spacecraft communications
- B. When the music produces no spurious emissions
- C. When the purpose is to interfere with an illegal transmission
- D. When the music is above 1280 MHz

T1D05 (A) [97.113(a)(3)]

When may amateur radio operators use their stations to notify other amateurs of the availability of equipment for sale or trade?

- A. When the equipment is normally used in an amateur station and such activity is not conducted on a regular basis
- B. When the asking price is \$100.00 or less
- C. When the asking price is less than its appraised value
- D. When the equipment is not the personal property of either the station licensee or the control operator or their close relatives

T1D06 (A) [97.113(a)(4)]

Which of the following types of transmissions are prohibited?

- A. Transmissions that contain obscene or indecent words or language
- B. Transmissions to establish one-way communications
- C. Transmissions to establish model aircraft control
- D. Transmissions for third party communications

T1D07 (B) [97.113(f)]

When is an amateur station authorized to automatically retransmit the radio signals of other amateur stations?

- A. When the signals are from an auxiliary, beacon, or Earth station
- B. When the signals are from an auxiliary, repeater, or space station
- C. When the signals are from a beacon, repeater, or space station
- D. When the signals are from an Earth, repeater, or space station

T1D08 (B) [97.113]

When may the control operator of an amateur station accept compensation?

- A. When engaging in communications on behalf of their employer
- B. When the communication is incidental to classroom instruction at an educational institution
- C. When re-broadcasting weather alerts during a RACES net
- D. When notifying other amateur operators of the availability for sale or trade of apparatus

T1D09 (A) [97.113(b)]

Under which of the following circumstances are amateur stations authorized to transmit signals related to broadcasting, program production, or news gathering, assuming no other means is available?

- A. Only where such communications directly relate to the immediate safety of human life or protection of property
- B. Only when broadcasting communications to or from the space shuttle.
- C. Only where noncommercial programming is gathered and supplied exclusively to the National Public Radio network

D. Only when using amateur repeaters linked to the Internet

T1D10 (D) [97.3(a)(10)]

What is the meaning of the term broadcasting in the FCC rules for the amateur services?

- A. Two-way transmissions by amateur stations
- B. Transmission of music
- C. Transmission of messages directed only to amateur operators
- D. Transmissions intended for reception by the general public

T1D11 (A) [97.113(a)(5)]

Which of the following types of communications are permitted in the Amateur Radio Service?

- A. Brief transmissions to make station adjustments
- B. Retransmission of entertainment programming from a commercial radio or TV station
- C. Retransmission of entertainment material from a public radio or TV station
- D. Communications on a regular basis that could reasonably be furnished alternatively through other radio services

T1E01 (A) [97.7(a)]

When must an amateur station have a control operator?

- A. Only when station is transmitting
- B. Only when the station is being locally controlled
- C. Only when the station is being remotely controlled
- D. Only when the station is being automatically controlled

T1E02 (D) [97.7(a)]

Who is eligible to be the control operator of an amateur station?

- A. Only a person holding an amateur service license from any country that belongs to the United Nations
- B. Only a citizen of the United States
- C. Only a person over the age of 18
- D. Only a person for whom an amateur operator/primary station license grant appears in the FCC database or who is authorized for alien reciprocal operation

T1E03 (A) [97.103(b)]

Who must designate the station control operator?

- A. The station licensee
- B. The FCC
- C. The frequency coordinator
- D. The ITU

T1E04 (D) [97.103(b)]

What determines the transmitting privileges of an amateur station?

- A. The frequency authorized by the frequency coordinator
- B. The class of operator license held by the station licensee
- C. The highest class of operator license held by anyone on the premises
- D. The class of operator license held by the control operator

T1E05 (C) [97.3(a)(14)]

What is an amateur station control point?

- A. The location of the station's transmitting antenna
- B. The location of the station transmitting apparatus and antenna structure
- C. The location at which the control operator function is performed
- D. The mailing address of the station licensee

T1E06 (B) [97.109(d)]

Under which of the following types of control is it permissible for the control operator to be at a location other than the control point?

- A. Local control
- B. Automatic control
- C. Remote control
- D. Indirect control

T1E07 (D) [97.103(a)]

When the control operator is not the station licensee, who is responsible for the proper operation of the station?

- A. All licensed amateurs who are present at the operation
- B. Only the station licensee
- C. Only the control operator
- D. The control operator and the station licensee are equally responsible

T1E08 (C) [97.3(a)]

What type of control is being used for a repeater when the control operator is not present at a control point?

- A. Local control
- B. Remote control
- C. Automatic control
- D. Unattended

T1E09 (D) [97.109(a)]

What type of control is being used when transmitting using a handheld radio?

- A. Radio control
- B. Unattended control
- C. Automatic control
- D. Local control

T1E10 (B) [97.3]

What type of control is used when the control operator is not at the station location but can indirectly manipulate the operating adjustments of a station?

- A. Local
- B. Remote
- C. Automatic
- D. Unattended

T1E11 (D) [97.103(a)]

Who does the FCC presume to be the control operator of an amateur station, unless documentation to the contrary is in the station records?

- A. The station custodian
- B. The third party participant
- C. The person operating the station equipment
- D. The station licensee

T1F01 (A)

What type of identification is being used when identifying a station on the air as "Race Headquarters"?

- A. Tactical call
- B. Self-assigned designator
- C. SSID
- D. Broadcast station

T1F02 (C) [97.119 (a)]

When using tactical identifiers, how often must your station transmit the station's FCC-assigned call sign?

- A. Never, the tactical call is sufficient

- B. Once during every hour
- C. Every ten minutes
- D. At the end of every communication

T1F03 (D) [97.119(a)]

When is an amateur station required to transmit its assigned call sign?

- A. At the beginning of each contact, and every 10 minutes thereafter
- B. At least once during each transmission
- C. At least every 15 minutes during and at the end of a contact
- D. At least every 10 minutes during and at the end of a contact

T1F04 (C) [97.119(b)]

Which of the following is an acceptable method of station identification when operating in the phone sub-band?

- A. By a phone emission in any language recognized by the United Nations
- B. By a phone emission in any language recognized by the ITU
- C. By a phone emission in the English language
- D. By a phone emission in English, French, or Spanish

T1F05 (B) [97.119(b)]

What method of call sign identification is required for a station transmitting phone signals?

- A. Send the call sign followed by the indicator RPT
- B. Send the call sign using CW or phone emission
- C. Send the call sign followed by the indicator R
- D. Send the call sign using only phone emission

T1F06 (D) [97.119(c)]

Which of the following uses of a self-assigned indicator is acceptable when identifying using a phone transmission?

- A. KL7CC stroke W3
- B. KL7CC slant W3
- C. KL7CC slash W3
- D. All of these choices are correct

T1F07 (D) [97.119(c)]

Which of the following restrictions apply when appending a self-assigned call sign indicator?

- A. It must be more than three letters and less than five letters
- B. It must be less than five letters
- C. It must start with the letters AA through AL, K, N, or W and be not less than two characters or more than five characters in length
- D. It must not conflict with any other indicator specified by the FCC rules or with any call sign prefix assigned to another country

T1F08 (A) [97.119(e)]

When may a Technician Class licensee be the control operator of a station operating in an exclusive Extra Class operator segment of the amateur bands?

- A. Never
- B. On Armed Forces Day
- C. As part of a multi-operator contest team
- D. When using a club station whose trustee is an Extra Class operator licensee

T1F09 (C) [97.3(a)(39)]

What type of amateur station simultaneously retransmits the signal of another amateur station on a different channel or channels?

- A. Beacon station
- B. Earth station
- C. Repeater station
- D. Message forwarding station

T1F10 (A) [97.205(g)]

Who is accountable should a repeater inadvertently retransmit communications that violate the FCC rules?

- A. The control operator of the originating station
- B. The control operator of the repeater
- C. The owner of the repeater
- D. Both the originating station and the repeater owner

T1F11 (A) [97.115(a)]

To which foreign stations do the FCC rules authorize the transmission of non-emergency third party communications?

- A. Any station whose government permits such communications
- B. Those in ITU Region 2 only
- C. Those in ITU Regions 2 and 3 only
- D. Those in ITU Region 3 only

T1F12 (B) [97.5(b)(2)]

How many persons are required to be members of a club for a club station license to be issued by the FCC?

- A. At least 5
- B. At least 4
- C. A trustee and 2 officers
- D. At least 2

T1F13 (B) [97.103(c)]

When must the station licensee make the station and its records available for FCC inspection?

- A. Any time upon request by an official observer
- B. Any time upon request by an FCC representative
- C. 30 days prior to renewal of the station license
- D. 10 days before the first transmission

T2A01 (B)

What is the most common repeater frequency offset in the 2 meter band?

- A. plus 500 kHz
- B. plus or minus 600 kHz
- C. minus 500 kHz
- D. Only plus 600 kHz

T2A02 (D)

What is the national calling frequency for FM simplex operations in the 70 cm band?

- A. 146.520 MHz
- B. 145.000 MHz
- C. 432.100 MHz
- D. 446.000 MHz

T2A03 (A)

What is a common repeater frequency offset in the 70 cm band?

- A. Plus or minus 5 MHz
- B. Plus or minus 600 kHz
- C. Minus 600 kHz
- D. Plus 600 kHz

T2A04 (B)

What is an appropriate way to call another station on a repeater if you know the other station's call sign?

- A. Say "break, break" then say the station's call sign
- B. Say the station's call sign then identify with your call sign

C. Say "CQ" three times then the other station's call sign

D. Wait for the station to call "CQ" then answer it

T2A05 (C)

What should you transmit when responding to a call of CQ?

- A. CQ followed by the other station's call sign
- B. Your call sign followed by the other station's call sign
- C. The other station's call sign followed by your call sign
- D. A signal report followed by your call sign

T2A06 (A)

What must an amateur operator do when making on-air transmissions to test equipment or antennas?

- A. Properly identify the transmitting station
- B. Make test transmissions only after 10:00 p.m. local time
- C. Notify the FCC of the test transmission
- D. State the purpose of the test during the test procedure

T2A07 (D)

Which of the following is true when making a test transmission?

- A. Station identification is not required if the transmission is less than 15 seconds
- B. Station identification is not required if the transmission is less than 1 watt
- C. Station identification is required only if your station can be heard
- D. Station identification is required at least every ten minutes during the test and at the end

T2A08 (D)

What is the meaning of the procedural signal "CQ"?

- A. Call on the quarter hour
- B. A new antenna is being tested (no station should answer)
- C. Only the called station should transmit
- D. Calling any station

T2A09 (B)

What brief statement is often used in place of "CQ" to indicate that you are listening on a repeater?

- A. Say "Hello test" followed by your call sign
- B. Say your call sign
- C. Say the repeater call sign followed by your call sign
- D. Say the letters "QSY" followed by your call sign

T2A10 (A)

What is a band plan, beyond the privileges established by the FCC?

- A. A voluntary guideline for using different modes or activities within an amateur band
- B. A mandated list of operating schedules
- C. A list of scheduled net frequencies
- D. A plan devised by a club to use a frequency band during a contest

T2A11 (D) [97.313(a)]

What are the FCC rules regarding power levels used in the amateur bands?

- A. Always use the maximum power allowed to ensure that you complete the contact
- B. An amateur may use no more than 200 watts PEP to make an amateur contact
- C. An amateur may use up to 1500 watts PEP on any amateur frequency
- D. An amateur must use the minimum transmitter power necessary to carry out the desired communication

T2B01 (C)

What is the term used to describe an amateur station that is transmitting and receiving on the same frequency?

- A. Full duplex communication
- B. Diplex communication
- C. Simplex communication
- D. Half duplex communication

T2B02 (D)

What is the term used to describe the use of a sub-audible tone transmitted with normal voice audio to open the squelch of a receiver?

- A. Carrier squelch
- B. Tone burst
- C. DTMF
- D. CTCSS

T2B03 (B)

Which of the following describes the muting of receiver audio controlled solely by the presence or absence of an RF signal?

- A. Tone squelch
- B. Carrier squelch
- C. CTCSS
- D. Modulated carrier

T2B04 (D)

What common problem causes you to be able to hear but not access a repeater even when transmitting with the proper offset?

- A. The repeater receiver requires audio tone burst for access
- B. The repeater receiver requires a CTCSS tone for access
- C. The repeater receiver may require a DCS tone sequence for access
- D. All of these choices are correct

T2B05 (C)

What determines the amount of deviation of an FM signal?

- A. Both the frequency and amplitude of the modulating signal
- B. The frequency of the modulating signal
- C. The amplitude of the modulating signal
- D. The relative phase of the modulating signal and the carrier

T2B06 (A)

What happens when the deviation of an FM transmitter is increased?

- A. Its signal occupies more bandwidth
- B. Its output power increases
- C. Its output power and bandwidth increases
- D. Asymmetric modulation occurs

T2B07 (D)

What should you do if you receive a report that your station's transmissions are causing splatter or interference on nearby frequencies?

- A. Increase transmit power
- B. Change mode of transmission
- C. Report the interference to the equipment manufacturer
- D. Check your transmitter for off-frequency operation or spurious emissions

T2B08 (B)

What is the proper course of action if your station's transmission unintentionally interferes with another station?

- A. Rotate your antenna slightly
- B. Properly identify your transmission and move to a different frequency
- C. Increase power
- D. Change antenna polarization

T2B09 (A) [97.119(b)(2)]

Which of the following methods is encouraged by the FCC when identifying your station when using phone?

- A. Use of a phonetic alphabet
- B. Send your call sign in CW as well as voice
- C. Repeat your call sign three times
- D. Increase your signal to full power when identifying

T2B10 (A)

What is the "Q" signal used to indicate that you are receiving interference from other stations?

- A. QRM
- B. QRN
- C. QTH
- D. QSB

T2B11 (B)

What is the "Q" signal used to indicate that you are changing frequency?

- A. QRU
- B. QSY
- C. QSL
- D. QRZ

T2C01 (C) [97.103(a)]

What set of rules applies to proper operation of your station when using amateur radio at the request of public service officials?

- A. RACES Rules
- B. ARES Rules
- C. FCC Rules
- D. FEMA Rules

T2C04 (D)

What do RACES and ARES have in common?

- A. They represent the two largest ham clubs in the United States
- B. Both organizations broadcast road and weather traffic information

C. Neither may handle emergency traffic supporting public service agencies

D. Both organizations may provide communications during emergencies

T2C05 (B) [97.3(a)(37), 97.407]

What is the Radio Amateur Civil Emergency Service?

A. An emergency radio service organized by amateur operators

B. A radio service using amateur stations for emergency management or civil defense communications

C. A radio service organized to provide communications at civic events

D. A radio service organized by amateur operators to assist non-military persons

T2C06 (C)

Which of the following is common practice during net operations to get the immediate attention of the net control station when reporting an emergency?

A. Repeat the words SOS three times followed by the call sign of the reporting station

B. Press the push-to-talk button three times

C. Begin your transmission with "Priority" or "Emergency" followed by your call sign

D. Play a pre-recorded emergency alert tone followed by your call sign

T2C07 (C)

What should you do to minimize disruptions to an emergency traffic net once you have checked in?

A. Whenever the net frequency is quiet, announce your call sign and location

B. Move 5 kHz away from the net's frequency and use high power to ask other hams to keep clear of the net frequency

C. Do not transmit on the net frequency until asked to do so by the net control station

D. Wait until the net frequency is quiet, then ask for any emergency traffic for your area

T2C08 (A)

What is usually considered to be the most important job of an amateur operator when handling emergency traffic messages?

A. Passing messages exactly as written, spoken or as received

- B. Estimating the number of people affected by the disaster
- C. Communicating messages to the news media for broadcast outside the disaster area
- D. Broadcasting emergency information to the general public

T2C09 (B) [97.403]

When may an amateur station use any means of radio communications at its disposal for essential communications in connection with immediate safety of human life and protection of property?

- A. Only when FEMA authorizes it by declaring an emergency
- B. When normal communications systems are not available
- C. Only when RACES authorizes it by declaring an emergency
- D. Only when authorized by the local MARS program director

T2C10 (D)

What is the preamble in a formal traffic message?

- A. The first paragraph of the message text
- B. The message number
- C. The priority handling indicator for the message
- D. The information needed to track the message as it passes through the amateur radio traffic handling system

T2C11 (A)

What is meant by the term "check" in reference to a formal traffic message?

- A. The check is a count of the number of words in the message
- B. The check is the value of a money order attached to the message
- C. The check is a list of stations that have relayed the message
- D. The check is a box on the message form that tells you the message was received

T3A01 (D)

What should you do if another operator reports that your stations' 2 meter signals were strong just a moment ago, but now they are weak or distorted?

- A. Change the batteries in your radio to a different type

- B. Turn on the CTCSS tone
- C. Ask the other operator to adjust his squelch control
- D. Try moving a few feet, as random reflections may be causing multi-path distortion

T3A02 (B)

Why are UHF signals often more effective from inside buildings than VHF signals?

- A. VHF signals lose power faster over distance
- B. The shorter wavelength allows them to more easily penetrate the structure of buildings
- C. This is incorrect; VHF works better than UHF inside buildings
- D. UHF antennas are more efficient than VHF antennas

T3A03 (C)

What antenna polarization is normally used for long-distance weak-signal CW and SSB contacts using the VHF and UHF bands?

- A. Right-hand circular
- B. Left-hand circular
- C. Horizontal
- D. Vertical

T3A04 (B)

What can happen if the antennas at opposite ends of a VHF or UHF line of sight radio link are not using the same polarization?

- A. The modulation sidebands might become inverted
- B. Signals could be significantly weaker
- C. Signals have an echo effect on voices
- D. Nothing significant will happen

T3A05 (B)

When using a directional antenna, how might your station be able to access a distant repeater if buildings or obstructions are blocking the direct line of sight path?

- A. Change from vertical to horizontal polarization
- B. Try to find a path that reflects signals to the repeater
- C. Try the long path
- D. Increase the antenna SWR

T3A06 (B)

What term is commonly used to describe the rapid fluttering sound sometimes heard from

mobile stations that are moving while transmitting?

- A. Flip-flopping
- B. Picket fencing
- C. Frequency shifting
- D. Pulsing

T3A07 (A)

What type of wave carries radio signals between transmitting and receiving stations?

- A. Electromagnetic
- B. Electrostatic
- C. Surface acoustic
- D. Magnetostrictive

T3A08 (C)

What is the cause of irregular fading of signals from distant stations during times of generally good reception?

- A. Absorption of signals by the "D" layer of the ionosphere
- B. Absorption of signals by the "E" layer of the ionosphere
- C. Random combining of signals arriving via different path lengths
- D. Intermodulation distortion in the local receiver

T3A09 (B)

Which is the common effect of "skip" reflections between the Earth and the ionosphere?

- A. The sidebands become reversed at each reflection
- B. The polarization of the original signal is randomized
- C. The apparent frequency of the received signal is shifted by a random amount
- D. Signals at frequencies above 30 MHz become stronger with each reflection

T3A10 (D)

What may occur if VHF or UHF data signals propagate over multiple paths?

- A. Transmission rates can be increased by a factor equal to the number of separate paths observed
- B. Transmission rates must be decreased by a factor equal to the number of separate paths observed
- C. No significant changes will occur if the signals are transmitting using FM

D. Error rates are likely to increase

T3A11 (C)

Which part of the atmosphere enables the propagation of radio signals around the world?

- A. The stratosphere
- B. The troposphere
- C. The ionosphere
- D. The magnetosphere

T3B01 (C)

What is the name for the distance a radio wave travels during one complete cycle?

- A. Wave speed
- B. Waveform
- C. Wavelength
- D. Wave spread

T3B02 (D)

What term describes the number of times per second that an alternating current reverses direction?

- A. Pulse rate
- B. Speed
- C. Wavelength
- D. Frequency

T3B03 (C)

What are the two components of a radio wave?

- A. AC and DC
- B. Voltage and current
- C. Electric and magnetic fields
- D. Ionizing and non-ionizing radiation

T3B04 (A)

How fast does a radio wave travel through free space?

- A. At the speed of light
- B. At the speed of sound
- C. Its speed is inversely proportional to its wavelength
- D. Its speed increases as the frequency increases

T3B05 (B)

How does the wavelength of a radio wave relate to its frequency?

- A. The wavelength gets longer as the frequency increases

- B. The wavelength gets shorter as the frequency increases
- C. There is no relationship between wavelength and frequency
- D. The wavelength depends on the bandwidth of the signal

T3B06 (D)

What is the formula for converting frequency to wavelength in meters?

- A. Wavelength in meters equals frequency in hertz multiplied by 300
- B. Wavelength in meters equals frequency in hertz divided by 300
- C. Wavelength in meters equals frequency in megahertz divided by 300
- D. Wavelength in meters equals 300 divided by frequency in megahertz

T3B07 (A)

What property of radio waves is often used to identify the different frequency bands?

- A. The approximate wavelength
- B. The magnetic intensity of waves
- C. The time it takes for waves to travel one mile
- D. The voltage standing wave ratio of waves

T3B08 (B)

What are the frequency limits of the VHF spectrum?

- A. 30 to 300 kHz
- B. 30 to 300 MHz
- C. 300 to 3000 kHz
- D. 300 to 3000 MHz

T3B09 (D)

What are the frequency limits of the UHF spectrum?

- A. 30 to 300 kHz
- B. 30 to 300 MHz
- C. 300 to 3000 kHz
- D. 300 to 3000 MHz

T3B10 (C)

What frequency range is referred to as HF?

- A. 300 to 3000 MHz
- B. 30 to 300 MHz
- C. 3 to 30 MHz
- D. 300 to 3000 kHz

T3B11 (B)

What is the approximate velocity of a radio wave as it travels through free space?

- A. 3000 kilometers per second
- B. 300,000,000 meters per second
- C. 300,000 miles per hour
- D. 186,000 miles per hour

T3C01 (C)

Why are "direct" (not via a repeater) UHF signals rarely heard from stations outside your local coverage area?

- A. They are too weak to go very far
- B. FCC regulations prohibit them from going more than 50 miles
- C. UHF signals are usually not reflected by the ionosphere
- D. They collide with trees and shrubbery and fade out

T3C02 (D)

Which of the following might be happening when VHF signals are being received from long distances?

- A. Signals are being reflected from outer space
- B. Signals are arriving by sub-surface ducting
- C. Signals are being reflected by lightning storms in our area
- D. Signals are being refracted from a sporadic E layer

T3C03 (B)

What is a characteristic of VHF signals received via auroral reflection?

- A. Signals from distances of 10,000 or more miles are common
- B. The signals exhibit rapid fluctuations of strength and often sound distorted
- C. These types of signals occur only during winter nighttime hours
- D. These types of signals are generally strongest when your antenna is aimed to the south (for stations in the Northern Hemisphere)

T3C04 (B)

Which of the following propagation types is most commonly associated with occasional strong over-the-horizon signals on the 10, 6, and 2 meter bands?

- A. Backscatter

- B. Sporadic E
- C. D layer absorption
- D. Gray-line propagation

T3C05 (C)

What is meant by the term "knife-edge" propagation?

- A. Signals are reflected back toward the originating station at acute angles
- B. Signals are sliced into several discrete beams and arrive via different paths
- C. Signals are partially refracted around solid objects exhibiting sharp edges
- D. Signals propagated close to the band edge exhibiting a sharp cutoff

T3C06 (A)

What mode is responsible for allowing over-the-horizon VHF and UHF communications to ranges of approximately 300 miles on a regular basis?

- A. Tropospheric scatter
- B. D layer refraction
- C. F2 layer refraction
- D. Faraday rotation

T3C07 (B)

What band is best suited to communicating via meteor scatter?

- A. 10 meters
- B. 6 meters
- C. 2 meters
- D. 70 cm

T3C08 (D)

What causes "tropospheric ducting"?

- A. Discharges of lightning during electrical storms
- B. Sunspots and solar flares
- C. Updrafts from hurricanes and tornadoes
- D. Temperature inversions in the atmosphere

T3C09 (A)

What is generally the best time for long-distance 10 meter band propagation?

- A. During daylight hours
- B. During nighttime hours
- C. When there are coronal mass ejections
- D. Whenever the solar flux is low

T3C10 (A)

What is the radio horizon?

- A. The distance at which radio signals between two points are effectively blocked by the curvature of the Earth
- B. The distance from the ground to a horizontally mounted antenna
- C. The farthest point you can see when standing at the base of your antenna tower
- D. The shortest distance between two points on the Earth's surface

T3C11 (C)

Why do VHF and UHF radio signals usually travel somewhat farther than the visual line of sight distance between two stations?

- A. Radio signals move somewhat faster than the speed of light
- B. Radio waves are not blocked by dust particles
- C. The Earth seems less curved to radio waves than to light
- D. Radio waves are blocked by dust particles

T4A01 (B)

Which of the following is true concerning the microphone connectors on amateur transceivers?

- A. All transceivers use the same microphone connector type
- B. Some connectors include push-to-talk and voltages for powering the microphone
- C. All transceivers using the same connector type are wired identically
- D. Un-keyed connectors allow any microphone to be connected

T4A02 (C)

What could be used in place of a regular speaker to help you copy signals in a noisy area?

- A. A video display
- B. A low pass filter
- C. A set of headphones
- D. A boom microphone

T4A03 (A)

Which is a good reason to use a regulated power supply for communications equipment?

- A. It prevents voltage fluctuations from reaching sensitive circuits
- B. A regulated power supply has FCC approval
- C. A fuse or circuit breaker regulates the power
- D. Power consumption is independent of load

T4A04 (A)

Where must a filter be installed to reduce harmonic emissions?

- A. Between the transmitter and the antenna
- B. Between the receiver and the transmitter
- C. At the station power supply
- D. At the microphone

T4A05 (D)

What type of filter should be connected to a TV receiver as the first step in trying to prevent RF overload from a nearby 2 meter transmitter?

- A. Low-pass filter
- B. High-pass filter
- C. Band-pass filter
- D. Band-reject filter

T4A06 (C)

Which of the following would be connected between a transceiver and computer in a packet radio station?

- A. Transmatch
- B. Mixer
- C. Terminal node controller
- D. Antenna

T4A07 (C)

How is the computer's sound card used when conducting digital communications using a computer?

- A. The sound card communicates between the computer CPU and the video display
- B. The sound card records the audio frequency for video display
- C. The sound card provides audio to the microphone input and converts received audio to digital form
- D. All of these choices are correct

T4A08 (D)

Which type of conductor is best to use for RF grounding?

- A. Round stranded wire
- B. Round copper-clad steel wire
- C. Twisted-pair cable
- D. Flat strap

T4A09 (D)

Which would you use to reduce RF current flowing on the shield of an audio cable?

- A. Band-pass filter
- B. Low-pass filter
- C. Preamplifier
- D. Ferrite choke

T4A10 (B)

What is the source of a high-pitched whine that varies with engine speed in a mobile transceiver's receive audio?

- A. The ignition system
- B. The alternator
- C. The electric fuel pump
- D. Anti-lock braking system controllers

T4A11 (A)

Where should a mobile transceiver's power negative connection be made?

- A. At the battery or engine block ground strap
- B. At the antenna mount
- C. To any metal part of the vehicle
- D. Through the transceiver's mounting bracket

T4B01 (B)

What may happen if a transmitter is operated with the microphone gain set too high?

- A. The output power might be too high
- B. The output signal might become distorted
- C. The frequency might vary
- D. The SWR might increase

T4B02 (A)

Which of the following can be used to enter the operating frequency on a modern transceiver?

- A. The keypad or VFO knob
- B. The CTCSS or DTMF encoder
- C. The Automatic Frequency Control
- D. All of these choices are correct

T4B03 (D)

What is the purpose of the squelch control on a transceiver?

- A. To set the highest level of volume desired
- B. To set the transmitter power level
- C. To adjust the automatic gain control
- D. To mute receiver output noise when no signal is being received

T4B04 (B)

What is a way to enable quick access to a favorite frequency on your transceiver?

- A. Enable the CTCSS tones
- B. Store the frequency in a memory channel
- C. Disable the CTCSS tones
- D. Use the scan mode to select the desired frequency

T4B05 (C)

Which of the following would reduce ignition interference to a receiver?

- A. Change frequency slightly
- B. Decrease the squelch setting
- C. Turn on the noise blanker
- D. Use the RIT control

T4B06 (D)

Which of the following controls could be used if the voice pitch of a single-sideband signal seems too high or low?

- A. The AGC or limiter
- B. The bandwidth selection
- C. The tone squelch
- D. The receiver RIT or clarifier

T4B07 (B)

What does the term "RIT" mean?

- A. Receiver Input Tone
- B. Receiver Incremental Tuning
- C. Rectifier Inverter Test
- D. Remote Input Transmitter

T4B08 (B)

What is the advantage of having multiple receive bandwidth choices on a multimode transceiver?

- A. Permits monitoring several modes at once
- B. Permits noise or interference reduction by selecting a bandwidth matching the mode
- C. Increases the number of frequencies that can be stored in memory
- D. Increases the amount of offset between receive and transmit frequencies

T4B09 (C)

Which of the following is an appropriate receive filter to select in order to minimize noise and interference for SSB reception?

- A. 500 Hz
- B. 1000 Hz
- C. 2400 Hz

D. 5000 Hz

T4B10 (A)

Which of the following is an appropriate receive filter to select in order to minimize noise and interference for CW reception?

- A. 500 Hz
- B. 1000 Hz
- C. 2400 Hz
- D. 5000 Hz

T4B11 (C)

Which of the following describes the common meaning of the term "repeater offset"?

- A. The distance between the repeater's transmit and receive antennas
- B. The time delay before the repeater timer resets
- C. The difference between the repeater's transmit and receive frequencies
- D. The maximum frequency deviation permitted on the repeater's input signal

T5A01 (D)

Electrical current is measured in which of the following units?

- A. Volts
- B. Watts
- C. Ohms
- D. Amperes

T5A02 (B)

Electrical power is measured in which of the following units?

- A. Volts
- B. Watts
- C. Ohms
- D. Amperes

T5A03 (D)

What is the name for the flow of electrons in an electric circuit?

- A. Voltage
- B. Resistance
- C. Capacitance
- D. Current

T5A04 (B)

What is the name for a current that flows only in one direction?

- A. Alternating current
- B. Direct current
- C. Normal current
- D. Smooth current

T5A05 (A)

What is the electrical term for the electromotive force (EMF) that causes electron flow?

- A. Voltage
- B. Ampere-hours
- C. Capacitance
- D. Inductance

T5A06 (A)

How much voltage does a mobile transceiver usually require?

- A. About 12 volts
- B. About 30 volts
- C. About 120 volts
- D. About 240 volts

T5A07 (C)

Which of the following is a good electrical conductor?

- A. Glass
- B. Wood
- C. Copper
- D. Rubber

T5A08 (B)

Which of the following is a good electrical insulator?

- A. Copper
- B. Glass
- C. Aluminum
- D. Mercury

T5A09 (A)

What is the name for a current that reverses direction on a regular basis?

- A. Alternating current
- B. Direct current
- C. Circular current
- D. Vertical current

T5A10 (C)

Which term describes the rate at which electrical energy is used?

- A. Resistance
- B. Current

- C. Power
- D. Voltage

T5A11 (A)

What is the basic unit of electromotive force?

- A. The volt
- B. The watt
- C. The ampere
- D. The ohm

T5B01 (C)

How many milliamperes is 1.5 amperes?

- A. 15 milliamperes
- B. 150 milliamperes
- C. 1,500 milliamperes
- D. 15,000 milliamperes

T5B02 (A)

What is another way to specify a radio signal frequency of 1,500,000 hertz?

- A. 1500 kHz
- B. 1500 MHz
- C. 15 GHz
- D. 150 kHz

T5B03 (C)

How many volts are equal to one kilovolt?

- A. one one-thousandth of a volt
- B. one hundred volts
- C. one thousand volts
- D. one million volts

T5B04 (A)

How many volts are equal to one microvolt?

- A. one one-millionth of a volt
- B. one million volts
- C. one thousand kilovolts
- D. one one-thousandth of a volt

T5B05 (B)

Which of the following is equivalent to 500 milliwatts?

- A. 0.02 watts
- B. 0.5 watts
- C. 5 watts
- D. 50 watts

T5B06 (C)

If an ammeter calibrated in amperes is used to measure a 3000-milliamper current, what

reading would it show?

- A. 0.003 amperes
- B. 0.3 amperes
- C. 3 amperes
- D. 3,000,000 amperes

T5B07 (C)

If a frequency readout calibrated in megahertz shows a reading of 3.525 MHz, what would it show if it were calibrated in kilohertz?

- A. 0.003525 kHz
- B. 35.25 kHz
- C. 3525 kHz
- D. 3,525,000 kHz

T5B08 (B)

How many microfarads are 1,000,000 picofarads?

- A. 0.001 microfarads
- B. 1 microfarad
- C. 1000 microfarads
- D. 1,000,000,000 microfarads

T5B09 (B)

What is the approximate amount of change, measured in decibels (dB), of a power increase from 5 watts to 10 watts?

- A. 2 dB
- B. 3 dB
- C. 5 dB
- D. 10 dB

T5B10 (C)

What is the approximate amount of change, measured in decibels (dB), of a power decrease from 12 watts to 3 watts?

- A. 1 dB
- B. 3 dB
- C. 6 dB
- D. 9 dB

T5B11 (A)

What is the approximate amount of change, measured in decibels (dB), of a power increase from 20 watts to 200 watts?

- A. 10 dB
- B. 12 dB
- C. 18 dB
- D. 28 dB

T5C01 (D)

What is the ability to store energy in an electric field called?

- A. Inductance
- B. Resistance
- C. Tolerance
- D. Capacitance

T5C02 (A)

What is the basic unit of capacitance?

- A. The farad
- B. The ohm
- C. The volt
- D. The henry

T5C03 (D)

What is the ability to store energy in a magnetic field called?

- A. Admittance
- B. Capacitance
- C. Resistance
- D. Inductance

T5C04 (C)

What is the basic unit of inductance?

- A. The coulomb
- B. The farad
- C. The henry
- D. The ohm

T5C05 (A)

What is the unit of frequency?

- A. Hertz
- B. Henry
- C. Farad
- D. Tesla

T5C06 (C)

What is the abbreviation that refers to radio frequency signals of all types?

- A. AF
- B. HF
- C. RF
- D. VHF

T5C07 (C)

What is the usual name for electromagnetic waves that travel through space?

- A. Gravity waves
- B. Sound waves

- C. Radio waves
- D. Pressure waves

T5C08 (A)

What is the formula used to calculate electrical power in a DC circuit?

- A. Power (P) equals voltage (E) multiplied by current (I)
- B. Power (P) equals voltage (E) divided by current (I)
- C. Power (P) equals voltage (E) minus current (I)
- D. Power (P) equals voltage (E) plus current (I)

T5C09 (A)

How much power is being used in a circuit when the applied voltage is 13.8 volts DC and the current is 10 amperes?

- A. 138 watts
- B. 0.7 watts
- C. 23.8 watts
- D. 3.8 watts

T5C10 (B)

How much power is being used in a circuit when the applied voltage is 12 volts DC and the current is 2.5 amperes?

- A. 4.8 watts
- B. 30 watts
- C. 14.5 watts
- D. 0.208 watts

T5C11 (B)

How many amperes are flowing in a circuit when the applied voltage is 12 volts DC and the load is 120 watts?

- A. 0.1 amperes
- B. 10 amperes
- C. 12 amperes
- D. 132 amperes

T5D01 (B)

What formula is used to calculate current in a circuit?

- A. Current (I) equals voltage (E) multiplied by resistance (R)
- B. Current (I) equals voltage (E) divided by resistance (R)
- C. Current (I) equals voltage (E) added to resistance (R)

D. Current (I) equals voltage (E) minus resistance (R)

T5D02 (A)

What formula is used to calculate voltage in a circuit?

- A. Voltage (E) equals current (I) multiplied by resistance (R)
- B. Voltage (E) equals current (I) divided by resistance (R)
- C. Voltage (E) equals current (I) added to resistance (R)
- D. Voltage (E) equals current (I) minus resistance (R)

T5D03 (B)

What formula is used to calculate resistance in a circuit?

- A. Resistance (R) equals voltage (E) multiplied by current (I)
- B. Resistance (R) equals voltage (E) divided by current (I)
- C. Resistance (R) equals voltage (E) added to current (I)
- D. Resistance (R) equals voltage (E) minus current (I)

T5D04 (B)

What is the resistance of a circuit in which a current of 3 amperes flows through a resistor connected to 90 volts?

- A. 3 ohms
- B. 30 ohms
- C. 93 ohms
- D. 270 ohms

T5D05 (C)

What is the resistance in a circuit for which the applied voltage is 12 volts and the current flow is 1.5 amperes?

- A. 18 ohms
- B. 0.125 ohms
- C. 8 ohms
- D. 13.5 ohms

T5D06 (A)

What is the resistance of a circuit that draws 4 amperes from a 12-volt source?

- A. 3 ohms
- B. 16 ohms

- C. 48 ohms
- D. 8 Ohms

T5D07 (D)

What is the current flow in a circuit with an applied voltage of 120 volts and a resistance of 80 ohms?

- A. 9600 amperes
- B. 200 amperes
- C. 0.667 amperes
- D. 1.5 amperes

T5D08 (C)

What is the current flowing through a 100-ohm resistor connected across 200 volts?

- A. 20,000 amperes
- B. 0.5 amperes
- C. 2 amperes
- D. 100 amperes

T5D09 (C)

What is the current flowing through a 24-ohm resistor connected across 240 volts?

- A. 24,000 amperes
- B. 0.1 amperes
- C. 10 amperes
- D. 216 amperes

T5D10 (A)

What is the voltage across a 2-ohm resistor if a current of 0.5 amperes flows through it?

- A. 1 volt
- B. 0.25 volts
- C. 2.5 volts
- D. 1.5 volts

T5D11 (B)

What is the voltage across a 10-ohm resistor if a current of 1 ampere flows through it?

- A. 1 volt
- B. 10 volts
- C. 11 volts
- D. 9 volts

T5D12 (D)

What is the voltage across a 10-ohm resistor if a current of 2 amperes flows through it?

- A. 8 volts
- B. 0.2 volts
- C. 12 volts

- D. 20 volts

T6A01 (B)

What electrical component is used to oppose the flow of current in a DC circuit?

- A. Inductor
- B. Resistor
- C. Voltmeter
- D. Transistor

T6A02 (C)

What type of component is often used as an adjustable volume control?

- A. Fixed resistor
- B. Power resistor
- C. Potentiometer
- D. Transformer

T6A03 (B)

What electrical parameter is controlled by a potentiometer?

- A. Inductance
- B. Resistance
- C. Capacitance
- D. Field strength

T6A04 (B)

What electrical component stores energy in an electric field?

- A. Resistor
- B. Capacitor
- C. Inductor
- D. Diode

T6A05 (D)

What type of electrical component consists of two or more conductive surfaces separated by an insulator?

- A. Resistor
- B. Potentiometer
- C. Oscillator
- D. Capacitor

T6A06 (C)

What type of electrical component stores energy in a magnetic field?

- A. Resistor
- B. Capacitor
- C. Inductor
- D. Diode

T6A07 (D)

What electrical component is usually composed of a coil of wire?

- A. Resistor
- B. Capacitor
- C. Diode
- D. Inductor

T6A08 (B)

What electrical component is used to connect or disconnect electrical circuits?

- A. Diode
- B. Switch
- C. Inductor
- D. Variable resistor

T6A09 (A)

What electrical component is used to protect other circuit components from current overloads?

- A. Fuse
- B. Capacitor
- C. Shield
- D. Inductor

T6A10 (B)

What is the nominal voltage of a fully charged nickel-cadmium cell?

- A. 1.0 volts
- B. 1.2 volts
- C. 1.5 volts
- D. 2.2 volts

T6A11 (B)

Which battery type is not rechargeable?

- A. Nickel-cadmium
- B. Carbon-zinc
- C. Lead-acid
- D. Lithium-ion

T6B01 (D)

What class of electronic components is capable of using a voltage or current signal to control current flow?

- A. Capacitors
- B. Inductors
- C. Resistors
- D. Transistors

T6B02 (C)

What electronic component allows current to flow in only one direction?

- A. Resistor
- B. Fuse
- C. Diode
- D. Driven Element

T6B03 (C)

Which of these components can be used as an electronic switch or amplifier?

- A. Oscillator
- B. Potentiometer
- C. Transistor
- D. Voltmeter

T6B04 (B)

Which of these components is made of three layers of semiconductor material?

- A. Alternator
- B. Bipolar junction transistor
- C. Triode
- D. Pentagrid converter

T6B05 (A)

Which of the following electronic components can amplify signals?

- A. Transistor
- B. Variable resistor
- C. Electrolytic capacitor
- D. Multi-cell battery

T6B06 (B)

How is a semiconductor diode's cathode lead usually identified?

- A. With the word "cathode"
- B. With a stripe
- C. With the letter "C"
- D. All of these choices are correct

T6B07 (B)

What does the abbreviation "LED" stand for?

- A. Low Emission Diode
- B. Light Emitting Diode
- C. Liquid Emission Detector
- D. Long Echo Delay

T6B08 (A)

What does the abbreviation "FET" stand for?

- A. Field Effect Transistor

- B. Fast Electron Transistor
- C. Free Electron Transition
- D. Field Emission Thickness

T6B09 (C)

What are the names of the two electrodes of a diode?

- A. Plus and minus
- B. Source and drain
- C. Anode and cathode
- D. Gate and base

T6B10 (A)

Which semiconductor component has an emitter electrode?

- A. Bipolar transistor
- B. Field effect transistor
- C. Silicon diode
- D. Bridge rectifier

T6B11 (B)

Which semiconductor component has a gate electrode?

- A. Bipolar transistor
- B. Field effect transistor
- C. Silicon diode
- D. Bridge rectifier

T6B12 (A)

What is the term that describes a transistor's ability to amplify a signal?

- A. Gain
- B. Forward resistance
- C. Forward voltage drop
- D. On resistance

T6C01 (C)

What is the name for standardized representations of components in an electrical wiring diagram?

- A. Electrical depictions
- B. Grey sketch
- C. Schematic symbols
- D. Component callouts

T6C02 (A)

What is component 1 in figure T1?

- A. Resistor
- B. Transistor
- C. Battery

D. Connector

T6C03 (B)

What is component 2 in figure T1?

- A. Resistor
- B. Transistor
- C. Indicator lamp
- D. Connector

T6C04 (C)

What is component 3 in figure T1?

- A. Resistor
- B. Transistor
- C. Lamp
- D. Ground symbol

T6C05 (C)

What is component 4 in figure T1?

- A. Resistor
- B. Transistor
- C. Battery
- D. Ground symbol

T6C06 (B)

What is component 6 in figure T2?

- A. Resistor
- B. Capacitor
- C. Regulator IC
- D. Transistor

T6C07 (D)

What is component 8 in figure T2?

- A. Resistor
- B. Inductor
- C. Regulator IC
- D. Light emitting diode

T6C08 (C)

What is component 9 in figure T2?

- A. Variable capacitor
- B. Variable inductor
- C. Variable resistor
- D. Variable transformer

T6C09 (D)

What is component 4 in figure T2?

- A. Variable inductor
- B. Double-pole switch
- C. Potentiometer
- D. Transformer

T6C10 (D)

What is component 3 in figure T3?

- A. Connector
- B. Meter
- C. Variable capacitor
- D. Variable inductor

T6C11 (A)

What is component 4 in figure T3?

- A. Antenna
- B. Transmitter
- C. Dummy load
- D. Ground

T6C12 (A)

What do the symbols on an electrical circuit schematic diagram represent?

- A. Electrical components
- B. Logic states
- C. Digital codes
- D. Traffic nodes

T6C13 (C)

Which of the following is accurately represented in electrical circuit schematic diagrams?

- A. Wire lengths
- B. Physical appearance of components
- C. The way components are interconnected
- D. All of these choices are correct

T6D01 (B)

Which of the following devices or circuits changes an alternating current into a varying direct current signal?

- A. Transformer
- B. Rectifier
- C. Amplifier
- D. Reflector

T6D02 (A)

What best describes a relay?

- A. A switch controlled by an electromagnet
- B. A current controlled amplifier
- C. An optical sensor
- D. A pass transistor

T6D03 (A)

What type of switch is represented by item 3 in figure T2?

- A. Single-pole single-throw
- B. Single-pole double-throw
- C. Double-pole single-throw
- D. Double-pole double-throw

T6D04 (C)

Which of the following can be used to display signal strength on a numeric scale?

- A. Potentiometer
- B. Transistor
- C. Meter
- D. Relay

T6D05 (A)

What type of circuit controls the amount of voltage from a power supply?

- A. Regulator
- B. Oscillator
- C. Filter
- D. Phase inverter

T6D06 (B)

What component is commonly used to change 120V AC house current to a lower AC voltage for other uses?

- A. Variable capacitor
- B. Transformer
- C. Transistor
- D. Diode

T6D07 (A)

Which of the following is commonly used as a visual indicator?

- A. LED
- B. FET
- C. Zener diode
- D. Bipolar transistor

T6D08 (D)

What of the following is used together with an inductor to make a tuned circuit?

- A. Resistor
- B. Zener diode
- C. Potentiometer
- D. Capacitor

T6D09 (C)

What is the name of a device that combines several semiconductors and other components into one package?

- A. Transducer
- B. Multi-pole relay
- C. Integrated circuit
- D. Transformer

T6D10 (C)

What is the function of component 2 in Figure T1?

- A. Give off light when current flows through it
- B. Supply electrical energy
- C. Control the flow of current
- D. Convert electrical energy into radio waves

T6D11 (B)

What of the following is a common use of coaxial cable?

- A. Carry dc power from a vehicle battery to a mobile radio
- B. Carry RF signals between a radio and antenna
- C. Secure masts, tubing, and other cylindrical objects on towers
- D. Connect data signals from a TNC to a computer

T7A01 (C)

What is the function of a product detector?

- A. Detect phase modulated signals
- B. Demodulate FM signals
- C. Detect CW and SSB signals
- D. Combine speech and RF signals

T7A02 (C)

What type of receiver is shown in Figure T6?

- A. Direct conversion
- B. Super-regenerative
- C. Single-conversion superheterodyne
- D. Dual-conversion superheterodyne

T7A03 (C)

What is the function of a mixer in a superheterodyne receiver?

- A. To reject signals outside of the desired passband
- B. To combine signals from several stations together
- C. To shift the incoming signal to an intermediate

frequency

D. To connect the receiver with an auxiliary device, such as a TNC

T7A04 (D)

What circuit is pictured in Figure T7, if block 1 is a frequency discriminator?

- A. A double-conversion receiver
- B. A regenerative receiver
- C. A superheterodyne receiver
- D. An FM receiver

T7A05 (D)

What is the function of block 1 if figure T4 is a simple CW transmitter?

- A. Reactance modulator
- B. Product detector
- C. Low-pass filter
- D. Oscillator

T7A06 (C)

What device takes the output of a low-powered 28 MHz SSB exciter and produces a 222 MHz output signal?

- A. High-pass filter
- B. Low-pass filter
- C. Transverter
- D. Phase converter

T7A07 (B)

If figure T5 represents a transceiver in which block 1 is the transmitter portion and block 3 is the receiver portion, what is the function of block 2?

- A. A balanced modulator
- B. A transmit-receive switch
- C. A power amplifier
- D. A high-pass filter

T7A08 (C)

Which of the following circuits combines a speech signal and an RF carrier?

- A. Beat frequency oscillator
- B. Discriminator
- C. Modulator
- D. Noise blanker

T7A09 (B)

Which of the following devices is most useful for VHF weak-signal communication?

- A. A quarter-wave vertical antenna
- B. A multi-mode VHF transceiver
- C. An omni-directional antenna
- D. A mobile VHF FM transceiver

T7A10 (B)

What device increases the low-power output from a handheld transceiver?

- A. A voltage divider
- B. An RF power amplifier
- C. An impedance network
- D. A voltage regulator

T7A11 (B)

Which of the following circuits demodulates FM signals?

- A. Limiter
- B. Discriminator
- C. Product detector
- D. Phase inverter

T7A12 (C)

Which term describes the ability of a receiver to discriminate between multiple signals?

- A. Tuning rate
- B. Sensitivity
- C. Selectivity
- D. Noise floor

T7A13 (A)

Where is an RF preamplifier installed?

- A. Between the antenna and receiver
- B. At the output of the transmitter's power amplifier
- C. Between a transmitter and antenna tuner
- D. At the receiver's audio output

T7B01 (D)

What can you do if you are told your FM handheld or mobile transceiver is over deviating?

- A. Talk louder into the microphone
- B. Let the transceiver cool off
- C. Change to a higher power level
- D. Talk farther away from the microphone

T7B02 (C)

What is meant by fundamental overload in reference to a receiver?

- A. Too much voltage from the power supply
- B. Too much current from the power supply

- C. Interference caused by very strong signals
- D. Interference caused by turning the volume up too high

T7B03 (D)

Which of the following may be a cause of radio frequency interference?

- A. Fundamental overload
- B. Harmonics
- C. Spurious emissions
- D. All of these choices are correct

T7B04 (B)

What is the most likely cause of interference to a telephone from a nearby transmitter?

- A. Harmonics from the transmitter
- B. The telephone is inadvertently acting as a radio receiver
- C. Poor station grounding
- D. Improper transmitter adjustment

T7B05 (C)

What is a logical first step when attempting to cure a radio frequency interference problem in a nearby telephone?

- A. Install a low-pass filter at the transmitter
- B. Install a high-pass filter at the transmitter
- C. Install an RF filter at the telephone
- D. Improve station grounding

T7B06 (A)

What should you do first if someone tells you that your transmissions are interfering with their radio or TV reception?

- A. Make sure that your station is operating properly and that it does not cause interference to your own television
- B. Immediately turn off your transmitter and contact the nearest FCC office for assistance
- C. Tell them that your license gives you the right to transmit and nothing can be done to reduce the interference
- D. Continue operating normally because your equipment cannot possibly cause any interference

T7B07 (D)

Which of the following may be useful in correcting a radio frequency interference problem?

- A. Snap-on ferrite chokes
- B. Low-pass and high-pass filters
- C. Band-reject and band-pass filters
- D. All of these choices are correct

T7B08 (D)

What should you do if a "Part 15" device in your neighbor's home is causing harmful interference to your amateur station?

- A. Work with your neighbor to identify the offending device
- B. Politely inform your neighbor about the rules that require him to stop using the device if it causes interference
- C. Check your station and make sure it meets the standards of good amateur practice
- D. All of these choices are correct

T7B09 (D)

What could be happening if another operator reports a variable high-pitched whine on the audio from your mobile transmitter?

- A. Your microphone is picking up noise from an open window
- B. You have the volume on your receiver set too high
- C. You need to adjust your squelch control
- D. Noise on the vehicle's electrical system is being transmitted along with your speech audio

T7B10 (D)

What might be the problem if you receive a report that your signal through the repeater is distorted or unintelligible?

- A. Your transmitter may be slightly off frequency
- B. Your batteries may be running low
- C. You could be in a bad location
- D. All of these choices are correct

T7B11 (C)

What is a symptom of RF feedback in a transmitter or transceiver?

- A. Excessive SWR at the antenna connection
- B. The transmitter will not stay on the desired frequency
- C. Reports of garbled, distorted, or unintelligible transmissions
- D. Frequent blowing of power supply fuses

T7B12 (C)

What does the acronym "BER" mean when applied to digital communications systems?

- A. Baud Enhancement Recovery
- B. Baud Error Removal
- C. Bit Error Rate
- D. Bit Exponent Resource

T7C01 (A)

What is the primary purpose of a dummy load?

- A. To prevent the radiation of signals when making tests
- B. To prevent over-modulation of your transmitter
- C. To improve the radiation from your antenna
- D. To improve the signal to noise ratio of your receiver

T7C02 (B)

Which of the following instruments can be used to determine if an antenna is resonant at the desired operating frequency?

- A. A VTVM
- B. An antenna analyzer
- C. A "Q" meter
- D. A frequency counter

T7C03 (A)

What, in general terms, is standing wave ratio (SWR)?

- A. A measure of how well a load is matched to a transmission line
- B. The ratio of high to low impedance in a feedline
- C. The transmitter efficiency ratio
- D. An indication of the quality of your station's ground connection

T7C04 (C)

What reading on an SWR meter indicates a perfect impedance match between the antenna and the feedline?

- A. 2 to 1
- B. 1 to 3
- C. 1 to 1
- D. 10 to 1

T7C05 (A)

What is the approximate SWR value above which the protection circuits in most solid-state transmitters begin to reduce transmitter power?

- A. 2 to 1

- B. 1 to 2
- C. 6 to 1
- D. 10 to 1

T7C06 (D)

What does an SWR reading of 4:1 mean?

- A. An antenna loss of 4 dB
- B. A good impedance match
- C. An antenna gain of 4
- D. An impedance mismatch

T7C07 (C)

What happens to power lost in a feedline?

- A. It increases the SWR
- B. It comes back into your transmitter and could cause damage
- C. It is converted into heat
- D. It can cause distortion of your signal

T7C08 (D)

What instrument other than an SWR meter could you use to determine if a feedline and antenna are properly matched?

- A. Voltmeter
- B. Ohmmeter
- C. Iambic pentameter
- D. Directional wattmeter

T7C09 (A)

Which of the following is the most common cause for failure of coaxial cables?

- A. Moisture contamination
- B. Gamma rays
- C. The velocity factor exceeds 1.0
- D. Overloading

T7C10 (D)

Why should the outer jacket of coaxial cable be resistant to ultraviolet light?

- A. Ultraviolet resistant jackets prevent harmonic radiation
- B. Ultraviolet light can increase losses in the cable's jacket
- C. Ultraviolet and RF signals can mix together, causing interference
- D. Ultraviolet light can damage the jacket and allow water to enter the cable

T7C11 (C)

What is a disadvantage of "air core" coaxial cable when compared to foam or solid dielectric types?

- A. It has more loss per foot
- B. It cannot be used for VHF or UHF antennas
- C. It requires special techniques to prevent water absorption
- D. It cannot be used at below freezing temperatures

T7D01 (B)

Which instrument would you use to measure electric potential or electromotive force?

- A. An ammeter
- B. A voltmeter
- C. A wavemeter
- D. An ohmmeter

T7D02 (B)

What is the correct way to connect a voltmeter to a circuit?

- A. In series with the circuit
- B. In parallel with the circuit
- C. In quadrature with the circuit
- D. In phase with the circuit

T7D03 (A)

How is an ammeter usually connected to a circuit?

- A. In series with the circuit
- B. In parallel with the circuit
- C. In quadrature with the circuit
- D. In phase with the circuit

T7D04 (D)

Which instrument is used to measure electric current?

- A. An ohmmeter
- B. A wavemeter
- C. A voltmeter
- D. An ammeter

T7D05 (D)

What instrument is used to measure resistance?

- A. An oscilloscope
- B. A spectrum analyzer
- C. A noise bridge
- D. An ohmmeter

T7D06 (C)

Which of the following might damage a

multimeter?

- A. Measuring a voltage too small for the chosen scale
- B. Leaving the meter in the milliamps position overnight
- C. Attempting to measure voltage when using the resistance setting
- D. Not allowing it to warm up properly

T7D07 (D)

Which of the following measurements are commonly made using a multimeter?

- A. SWR and RF power
- B. Signal strength and noise
- C. Impedance and reactance
- D. Voltage and resistance

T7D08 (C)

Which of the following types of solder is best for radio and electronic use?

- A. Acid-core solder
- B. Silver solder
- C. Rosin-core solder
- D. Aluminum solder

T7D09 (C)

What is the characteristic appearance of a "cold" solder joint?

- A. Dark black spots
- B. A bright or shiny surface
- C. A grainy or dull surface
- D. A greenish tint

T7D10 (B)

What is probably happening when an ohmmeter, connected across a circuit, initially indicates a low resistance and then shows increasing resistance with time?

- A. The ohmmeter is defective
- B. The circuit contains a large capacitor
- C. The circuit contains a large inductor
- D. The circuit is a relaxation oscillator

T7D11 (B)

Which of the following precautions should be taken when measuring circuit resistance with an ohmmeter?

- A. Ensure that the applied voltages are correct
- B. Ensure that the circuit is not powered
- C. Ensure that the circuit is grounded

D. Ensure that the circuit is operating at the correct frequency

T8A01 (C)

Which of the following is a form of amplitude modulation?

- A. Spread-spectrum
- B. Packet radio
- C. Single sideband
- D. Phase shift keying

T8A02 (A)

What type of modulation is most commonly used for VHF packet radio transmissions?

- A. FM
- B. SSB
- C. AM
- D. Spread Spectrum

T8A03 (C)

Which type of voice modulation is most often used for long-distance or weak signal contacts on the VHF and UHF bands?

- A. FM
- B. AM
- C. SSB
- D. PM

T8A04 (D)

Which type of modulation is most commonly used for VHF and UHF voice repeaters?

- A. AM
- B. SSB
- C. PSK
- D. FM

T8A05 (C)

Which of the following types of emission has the narrowest bandwidth?

- A. FM voice
- B. SSB voice
- C. CW
- D. Slow-scan TV

T8A06 (A)

Which sideband is normally used for 10 meter HF, VHF and UHF single-sideband communications?

- A. Upper sideband
- B. Lower sideband

- C. Suppressed sideband
- D. Inverted sideband

T8A07 (C)

What is the primary advantage of single sideband over FM for voice transmissions?

- A. SSB signals are easier to tune
- B. SSB signals are less susceptible to interference
- C. SSB signals have narrower bandwidth
- D. All of these choices are correct

T8A08 (B)

What is the approximate bandwidth of a single sideband voice signal?

- A. 1 kHz
- B. 3 kHz
- C. 6 kHz
- D. 15 kHz

T8A09 (C)

What is the approximate bandwidth of a VHF repeater FM phone signal?

- A. Less than 500 Hz
- B. About 150 kHz
- C. Between 5 and 15 kHz
- D. Between 50 and 125 kHz

T8A10 (B)

What is the typical bandwidth of analog fast-scan TV transmissions on the 70 cm band?

- A. More than 10 MHz
- B. About 6 MHz
- C. About 3 MHz
- D. About 1 MHz

T8A11 (B)

What is the approximate maximum bandwidth required to transmit a CW signal?

- A. 2.4 kHz
- B. 150 Hz
- C. 1000 Hz
- D. 15 kHz

T8B01 (D)

Who may be the control operator of a station communicating through an amateur satellite or space station?

- A. Only an Amateur Extra Class operator
- B. A General Class licensee or higher licensee

who has a satellite operator certification

- C. Only an Amateur Extra Class operator who is also an AMSAT member
- D. Any amateur whose license privileges allow them to transmit on the satellite uplink frequency

T8B02 (B) [97.313(a)]

How much transmitter power should be used on the uplink frequency of an amateur satellite or space station?

- A. The maximum power of your transmitter
- B. The minimum amount of power needed to complete the contact
- C. No more than half the rating of your linear amplifier
- D. Never more than 1 watt

T8B03 (A)

Which of the following can be done using an amateur radio satellite?

- A. Talk to amateur radio operators in other countries
- B. Get global positioning information
- C. Make telephone calls
- D. All of these choices are correct

T8B04 (B)

Which amateur stations may make contact with an amateur station on the International Space Station using amateur radio frequencies?

- A. Only members of amateur radio clubs at NASA facilities
- B. Any amateur holding a Technician or higher class license
- C. Only the astronaut's family members who are hams
- D. You cannot talk to the ISS on amateur radio frequencies

T8B05 (D)

What is a satellite beacon?

- A. The primary transmit antenna on the satellite
- B. An indicator light that shows where to point your antenna
- C. A reflective surface on the satellite
- D. A transmission from a space station that contains information about a satellite

T8B06 (D)

What can be used to determine the time period

during which an amateur satellite or space station can be accessed?

- A. A GPS receiver
- B. A field strength meter
- C. A telescope
- D. A satellite tracking program

T8B07 (C)

What is Doppler shift?

- A. A change in the satellite orbit
- B. A mode where the satellite receives signals on one band and transmits on another
- C. A change in signal frequency caused by motion of the transmitting station
- D. A special digital communications mode for some satellites

T8B08 (B)

What is meant by the statement that a satellite is operating in "mode U/V"?

- A. The satellite uplink is in the 15 meter band and the downlink is in the 10 meter band
- B. The satellite uplink is in the 70 cm band and the downlink is in the 2 meter band
- C. The satellite operates using ultraviolet frequencies
- D. The satellite frequencies are usually variable

T8B09 (B)

What causes "spin fading" when referring to satellite signals?

- A. Circular polarized noise interference radiated from the sun
- B. Rotation of the satellite and its antennas
- C. Doppler shift of the received signal
- D. Interfering signals within the satellite uplink band

T8B10 (C)

What do the initials LEO tell you about an amateur satellite?

- A. The satellite battery is in Low Energy Operation mode
- B. The satellite is performing a Lunar Ejection Orbit maneuver
- C. The satellite is in a Low Earth Orbit
- D. The satellite uses Light Emitting Optics

T8B11 (C)

What is a commonly used method of sending signals to and from a digital satellite?

- A. USB AFSK
- B. PSK31
- C. FM Packet
- D. WSJT

T8C01 (C)

Which of the following methods is used to locate sources of noise interference or jamming?

- A. Echolocation
- B. Doppler radar
- C. Radio direction finding
- D. Phase locking

T8C02 (B)

Which of these items would be useful for a hidden transmitter hunt?

- A. Calibrated SWR meter
- B. A directional antenna
- C. A calibrated noise bridge
- D. All of these choices are correct

T8C03 (A)

What popular operating activity involves contacting as many stations as possible during a specified period of time?

- A. Contesting
- B. Net operations
- C. Public service events
- D. Simulated emergency exercises

T8C04 (C)

Which of the following is good procedure when contacting another station in a radio contest?

- A. Be sure to sign only the last two letters of your call if there is a pileup calling the station
- B. Work the station twice to be sure that you are in his log
- C. Send only the minimum information needed for proper identification and the contest exchange
- D. All of these choices are correct

T8C05 (A)

What is a grid locator?

- A. A letter-number designator assigned to a geographic location
- B. A letter-number designator assigned to an azimuth and elevation

- C. An instrument for neutralizing a final amplifier
- D. An instrument for radio direction finding

T8C06 (C)

- For what purpose is a temporary "1 by 1" format (letter-number-letter) call sign assigned?
- A. To designate an experimental station
 - B. To honor a deceased relative who was a radio amateur
 - C. For operations in conjunction with an activity of special significance to the amateur community
 - D. All of these choices are correct

T8C07 (B) [97.215(c)]

- What is the maximum power allowed when transmitting telecommand signals to radio controlled models?
- A. 500 milliwatts
 - B. 1 watt
 - C. 25 watts
 - D. 1500 watts

T8C08 (C) [97.215(a)]

- What is required in place of on-air station identification when sending signals to a radio control model using amateur frequencies?
- A. Voice identification must be transmitted every 10 minutes
 - B. Morse code ID must be sent once per hour
 - C. A label indicating the licensee's call sign and address must be affixed to the transmitter
 - D. A flag must be affixed to the transmitter antenna with the station call sign in 1 inch high letters or larger

T8C09 (C)

- How might you obtain a list of active nodes that use VoIP?
- A. From the FCC Rulebook
 - B. From your local emergency coordinator
 - C. From a repeater directory
 - D. From the local repeater frequency coordinator

T8C10 (D)

- How do you select a specific IRLP node when using a portable transceiver?
- A. Choose a specific CTCSS tone
 - B. Choose the correct DSC tone
 - C. Access the repeater autopatch
 - D. Use the keypad to transmit the IRLP node ID

T8C11 (A)

- What name is given to an amateur radio station that is used to connect other amateur stations to the Internet?
- A. A gateway
 - B. A repeater
 - C. A digipeater
 - D. A beacon

T8D01 (D)

- Which of the following is an example of a digital communications method?
- A. Packet
 - B. PSK31
 - C. MFSK
 - D. All of these choices are correct

T8D02 (A)

- What does the term APRS mean?
- A. Automatic Position Reporting System
 - B. Associated Public Radio Station
 - C. Auto Planning Radio Set-up
 - D. Advanced Polar Radio System

T8D03 (D)

- Which of the following is normally used when sending automatic location reports via amateur radio?
- A. A connection to the vehicle speedometer
 - B. A WWV receiver
 - C. A connection to a broadcast FM sub-carrier receiver
 - D. A Global Positioning System receiver

T8D04 (C)

- What type of transmission is indicated by the term NTSC?
- A. A Normal Transmission mode in Static Circuit
 - B. A special mode for earth satellite uplink
 - C. An analog fast scan color TV signal
 - D. A frame compression scheme for TV signals

T8D05 (B)

- Which of the following emission modes may be used by a Technician Class operator between 219 and 220 MHz?
- A. Spread spectrum
 - B. Data
 - C. SSB voice

D. Fast-scan television

T8D06 (B)

What does the abbreviation PSK mean?

- A. Pulse Shift Keying
- B. Phase Shift Keying
- C. Packet Short Keying
- D. Phased Slide Keying

T8D07 (D)

What is PSK31?

- A. A high-rate data transmission mode
- B. A method of reducing noise interference to FM signals
- C. A method of compressing digital television signal
- D. A low-rate data transmission mode

T8D08 (D)

What is included in packet transmissions?

- A. A check sum which permits error detection
- B. A header which contains the call sign of the station to which the information is being sent
- C. Automatic repeat request in case of error
- D. All of these choices are correct

T8D09 (C)

What digital code is used when sending CW in the amateur bands?

- A. Baudot
- B. Hamming
- C. Morse
- D. Gray

T8D10 (D)

Which of the following can be used to transmit CW in the amateur bands?

- A. Straight Key
- B. Electronic Keyer
- C. Computer Keyboard
- D. All of these choices are correct

T8D11 (C)

What is a "parity" bit?

- A. A control code required for automatic position reporting
- B. A timing bit used to ensure equal sharing of a frequency
- C. An extra code element used to detect errors in received data

D. A "triple width" bit used to signal the end of a character

T9A01 (C)

What is a beam antenna?

- A. An antenna built from aluminum I-beams
- B. An omnidirectional antenna invented by Clarence Beam
- C. An antenna that concentrates signals in one direction
- D. An antenna that reverses the phase of received signals

T9A02 (B)

Which of the following is true regarding vertical antennas?

- A. The magnetic field is perpendicular to the Earth
- B. The electric field is perpendicular to the Earth
- C. The phase is inverted
- D. The phase is reversed

T9A03 (B)

Which of the following describes a simple dipole mounted so the conductor is parallel to the Earth's surface?

- A. A ground wave antenna
- B. A horizontally polarized antenna
- C. A rhombic antenna
- D. A vertically polarized antenna

T9A04 (A)

What is a disadvantage of the "rubber duck" antenna supplied with most handheld radio transceivers?

- A. It does not transmit or receive as effectively as a full-sized antenna
- B. It transmits a circularly polarized signal
- C. If the rubber end cap is lost it will unravel very quickly
- D. All of these choices are correct

T9A05 (C)

How would you change a dipole antenna to make it resonant on a higher frequency?

- A. Lengthen it
- B. Insert coils in series with radiating wires
- C. Shorten it
- D. Add capacity hats to the ends of the radiating wires

T9A06 (C)

What type of antennas are the quad, Yagi, and dish?

- A. Non-resonant antennas
- B. Loop antennas
- C. Directional antennas
- D. Isotropic antennas

T9A07 (A)

What is a good reason not to use a "rubber duck" antenna inside your car?

- A. Signals can be significantly weaker than when it is outside of the vehicle
- B. It might cause your radio to overheat
- C. The SWR might decrease, decreasing the signal strength
- D. All of these choices are correct

T9A08 (C)

What is the approximate length, in inches, of a quarter-wavelength vertical antenna for 146 MHz?

- A. 112
- B. 50
- C. 19
- D. 12

T9A09 (C)

What is the approximate length, in inches, of a 6 meter 1/2-wavelength wire dipole antenna?

- A. 6
- B. 50
- C. 112
- D. 236

T9A10 (C)

In which direction is the radiation strongest from a half-wave dipole antenna in free space?

- A. Equally in all directions
- B. Off the ends of the antenna
- C. Broadside to the antenna
- D. In the direction of the feedline

T9A11 (C)

What is meant by the gain of an antenna?

- A. The additional power that is added to the transmitter power
- B. The additional power that is lost in the antenna when transmitting on a higher frequency

- C. The increase in signal strength in a specified direction when compared to a reference antenna
- D. The increase in impedance on receive or transmit compared to a reference antenna

T9B01 (B)

Why is it important to have a low SWR in an antenna system that uses coaxial cable feedline?

- A. To reduce television interference
- B. To allow the efficient transfer of power and reduce losses
- C. To prolong antenna life
- D. All of these choices are correct

T9B02 (B)

What is the impedance of the most commonly used coaxial cable in typical amateur radio installations?

- A. 8 ohms
- B. 50 ohms
- C. 600 ohms
- D. 12 ohms

T9B03 (A)

Why is coaxial cable used more often than any other feedline for amateur radio antenna systems?

- A. It is easy to use and requires few special installation considerations
- B. It has less loss than any other type of feedline
- C. It can handle more power than any other type of feedline
- D. It is less expensive than any other types of feedline

T9B04 (A)

What does an antenna tuner do?

- A. It matches the antenna system impedance to the transceiver's output impedance
- B. It helps a receiver automatically tune in weak stations
- C. It allows an antenna to be used on both transmit and receive
- D. It automatically selects the proper antenna for the frequency band being used

T9B05 (D)

What generally happens as the frequency of a signal passing through coaxial cable is increased?

- A. The apparent SWR increases
- B. The reflected power increases
- C. The characteristic impedance increases
- D. The loss increases

T9B06 (B)

Which of the following connectors is most suitable for frequencies above 400 MHz?

- A. A UHF (PL-259/SO-239) connector
- B. A Type N connector
- C. An RS-213 connector
- D. A DB-23

T9B07 (C)

Which of the following is true of PL-259 type coax connectors?

- A. They are good for UHF frequencies
- B. They are water tight
- C. They are commonly used at HF frequencies
- D. They are a bayonet type connector

T9B08 (A)

Why should coax connectors exposed to the weather be sealed against water intrusion?

- A. To prevent an increase in feedline loss
- B. To prevent interference to telephones
- C. To keep the jacket from becoming loose
- D. All of these choices are correct

T9B09 (B)

What might cause erratic changes in SWR readings?

- A. The transmitter is being modulated
- B. A loose connection in an antenna or a feedline
- C. The transmitter is being over-modulated
- D. Interference from other stations is distorting your signal

T9B10 (C)

What electrical difference exists between the smaller RG-58 and larger RG-8 coaxial cables?

- A. There is no significant difference between the two types
- B. RG-58 cable has less loss at a given frequency
- C. RG-8 cable has less loss at a given frequency
- D. RG-58 cable can handle higher power levels

T9B11 (C)

Which of the following types of feedline has the lowest loss at VHF and UHF?

- A. 50-ohm flexible coax
- B. Multi-conductor unbalanced cable
- C. Air-insulated hard line
- D. 75-ohm flexible coax

T0A01 (B)

Which is a commonly accepted value for the lowest voltage that can cause a dangerous electric shock?

- A. 12 volts
- B. 30 volts
- C. 120 volts
- D. 300 volts

T0A02 (D)

How does current flowing through the body cause a health hazard?

- A. By heating tissue
- B. It disrupts the electrical functions of cells
- C. It causes involuntary muscle contractions
- D. All of these choices are correct

T0A03 (C)

What is connected to the green wire in a three-wire electrical AC plug?

- A. Neutral
- B. Hot
- C. Safety ground
- D. The white wire

T0A04 (B)

What is the purpose of a fuse in an electrical circuit?

- A. To prevent power supply ripple from damaging a circuit
- B. To interrupt power in case of overload
- C. To limit current to prevent shocks
- D. All of these choices are correct

T0A05 (C)

Why is it unwise to install a 20-ampere fuse in the place of a 5-ampere fuse?

- A. The larger fuse would be likely to blow because it is rated for higher current
- B. The power supply ripple would greatly increase
- C. Excessive current could cause a fire
- D. All of these choices are correct

T0A06 (D)

What is a good way to guard against electrical shock at your station?

- A. Use three-wire cords and plugs for all AC powered equipment
- B. Connect all AC powered station equipment to a common safety ground
- C. Use a circuit protected by a ground-fault interrupter
- D. All of these choices are correct

T0A07 (D)

Which of these precautions should be taken when installing devices for lightning protection in a coaxial cable feedline?

- A. Include a parallel bypass switch for each protector so that it can be switched out of the circuit when running high power
- B. Include a series switch in the ground line of each protector to prevent RF overload from inadvertently damaging the protector
- C. Keep the ground wires from each protector separate and connected to station ground
- D. Ground all of the protectors to a common plate which is in turn connected to an external ground

T0A08 (C)

What is one way to recharge a 12-volt lead-acid station battery if the commercial power is out?

- A. Cool the battery in ice for several hours
- B. Add acid to the battery
- C. Connect the battery to a car's battery and run the engine
- D. All of these choices are correct

T0A09 (C)

What kind of hazard is presented by a conventional 12-volt storage battery?

- A. It emits ozone which can be harmful to the atmosphere
- B. Shock hazard due to high voltage
- C. Explosive gas can collect if not properly vented
- D. All of these choices are correct

T0A10 (A)

What can happen if a lead-acid storage battery is charged or discharged too quickly?

- A. The battery could overheat and give off flammable gas or explode
- B. The voltage can become reversed
- C. The "memory effect" will reduce the capacity of the battery
- D. All of these choices are correct

T0A11 (C)

Which of the following is good practice when installing ground wires on a tower for lightning protection?

- A. Put a loop in the ground connection to prevent water damage to the ground system
- B. Make sure that all bends in the ground wires are clean, right angle bends
- C. Ensure that connections are short and direct
- D. All of these choices are correct

T0A12 (D)

What kind of hazard might exist in a power supply when it is turned off and disconnected?

- A. Static electricity could damage the grounding system
- B. Circulating currents inside the transformer might cause damage
- C. The fuse might blow if you remove the cover
- D. You might receive an electric shock from stored charge in large capacitors

T0A13 (A)

What safety equipment should always be included in home-built equipment that is powered from 120V AC power circuits?

- A. A fuse or circuit breaker in series with the AC "hot" conductor
- B. An AC voltmeter across the incoming power source
- C. An inductor in series with the AC power source
- D. A capacitor across the AC power source

T0B01 (C)

When should members of a tower work team wear a hard hat and safety glasses?

- A. At all times except when climbing the tower
- B. At all times except when belted firmly to the tower
- C. At all times when any work is being done on the tower

D. At all times when the tower exceeds 30 feet in height

T0B02 (C)

What is a good precaution to observe before climbing an antenna tower?

- A. Make sure that you wear a grounded wrist strap
- B. Remove all tower grounding connections
- C. Put on a climbing harness and safety glasses
- D. All of these choices are correct

T0B03 (D)

Under what circumstances is it safe to climb a tower without a helper or observer?

- A. When no electrical work is being performed
- B. When no mechanical work is being performed
- C. When the work being done is not more than 20 feet above the ground
- D. Never

T0B04 (C)

Which of the following is an important safety precaution to observe when putting up an antenna tower?

- A. Wear a ground strap connected to your wrist at all times
- B. Insulate the base of the tower to avoid lightning strikes
- C. Look for and stay clear of any overhead electrical wires
- D. All of these choices are correct

T0B05 (C)

What is the purpose of a gin pole?

- A. To temporarily replace guy wires
- B. To be used in place of a safety harness
- C. To lift tower sections or antennas
- D. To provide a temporary ground

T0B06 (D)

What is the minimum safe distance from a power line to allow when installing an antenna?

- A. Half the width of your property
- B. The height of the power line above ground
- C. 1/2 wavelength at the operating frequency
- D. So that if the antenna falls unexpectedly, no part of it can come closer than 10 feet to the power wires

T0B07 (C)

Which of the following is an important safety rule to remember when using a crank-up tower?

- A. This type of tower must never be painted
- B. This type of tower must never be grounded
- C. This type of tower must never be climbed unless it is in the fully retracted position
- D. All of these choices are correct

T0B08 (C)

What is considered to be a proper grounding method for a tower?

- A. A single four-foot ground rod, driven into the ground no more than 12 inches from the base
- B. A ferrite-core RF choke connected between the tower and ground
- C. Separate eight-foot long ground rods for each tower leg, bonded to the tower and each other
- D. A connection between the tower base and a cold water pipe

T0B09 (C)

Why should you avoid attaching an antenna to a utility pole?

- A. The antenna will not work properly because of induced voltages
- B. The utility company will charge you an extra monthly fee
- C. The antenna could contact high-voltage power wires
- D. All of these choices are correct

T0B10 (C)

Which of the following is true concerning grounding conductors used for lightning protection?

- A. Only non-insulated wire must be used
- B. Wires must be carefully routed with precise right-angle bends
- C. Sharp bends must be avoided
- D. Common grounds must be avoided

T0B11 (B)

Which of the following establishes grounding requirements for an amateur radio tower or antenna?

- A. FCC Part 97 Rules
- B. Local electrical codes
- C. FAA tower lighting regulations

D. Underwriters Laboratories' recommended practices

T0C01 (D)

What type of radiation are VHF and UHF radio signals?

- A. Gamma radiation
- B. Ionizing radiation
- C. Alpha radiation
- D. Non-ionizing radiation

T0C02 (B)

Which of the following frequencies has the lowest Maximum Permissible Exposure limit?

- A. 3.5 MHz
- B. 50 MHz
- C. 440 MHz
- D. 1296 MHz

T0C03 (C)

What is the maximum power level that an amateur radio station may use at frequencies above 30 MHz before an RF exposure evaluation is required?

- A. 1500 watts PEP transmitter output
- B. 1 watt forward power
- C. 50 watts PEP at the antenna
- D. 50 watts PEP reflected power

T0C04 (D)

What factors affect the RF exposure of people near an amateur station antenna?

- A. Frequency and power level of the RF field
- B. Distance from the antenna to a person
- C. Radiation pattern of the antenna
- D. All of these choices are correct

T0C05 (D)

Why do exposure limits vary with frequency?

- A. Lower frequency RF fields have more energy than higher frequency fields
- B. Lower frequency RF fields do not penetrate the human body
- C. Higher frequency RF fields are transient in nature
- D. The human body absorbs more RF energy at some frequencies than at others

T0C06 (D)

Which of the following is an acceptable method to determine that your station complies with FCC RF exposure regulations?

- A. By calculation based on FCC OET Bulletin 65
- B. By calculation based on computer modeling
- C. By measurement of field strength using calibrated equipment
- D. All of these choices are correct

T0C07 (B)

What could happen if a person accidentally touched your antenna while you were transmitting?

- A. Touching the antenna could cause television interference
- B. They might receive a painful RF burn
- C. They might develop radiation poisoning
- D. All of these choices are correct

T0C08 (A)

Which of the following actions might amateur operators take to prevent exposure to RF radiation in excess of FCC-supplied limits?

- A. Relocate antennas
- B. Relocate the transmitter
- C. Increase the duty cycle
- D. All of these choices are correct

T0C09 (B)

How can you make sure your station stays in compliance with RF safety regulations?

- A. By informing the FCC of any changes made in your station
- B. By re-evaluating the station whenever an item of equipment is changed
- C. By making sure your antennas have low SWR
- D. All of these choices are correct

T0C10 (A)

Why is duty cycle one of the factors used to determine safe RF radiation exposure levels?

- A. It affects the average exposure of people to radiation
- B. It affects the peak exposure of people to radiation
- C. It takes into account the antenna feedline loss
- D. It takes into account the thermal effects of the final amplifier

T0C11 (C)

What is meant by "duty cycle" when referring to RF exposure?

- A. The difference between lowest usable output and maximum rated output power of a transmitter
- B. The difference between PEP and average power of an SSB signal
- C. The ratio of "on" time to "off" time of a transmitted signal
- D. The amount of time the operator spends transmitting

Graphics for 2010 Technician Question Pool –
Exam Element 2
Effective July 1, 2010

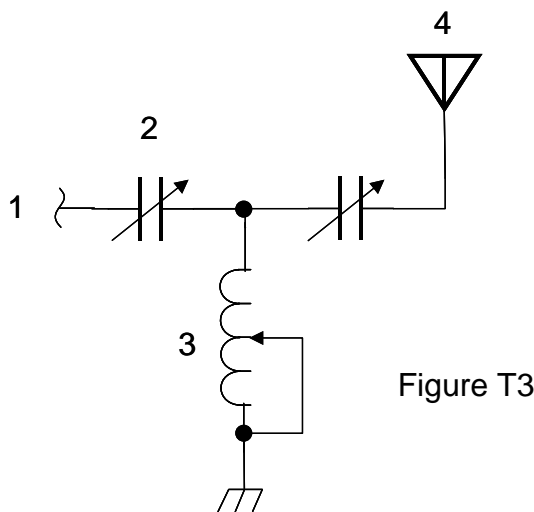
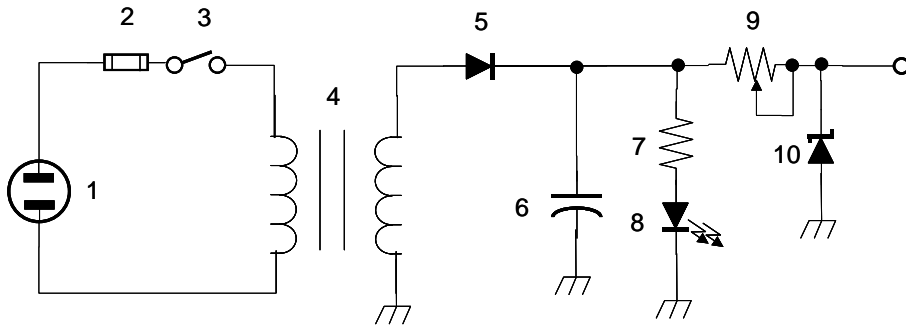
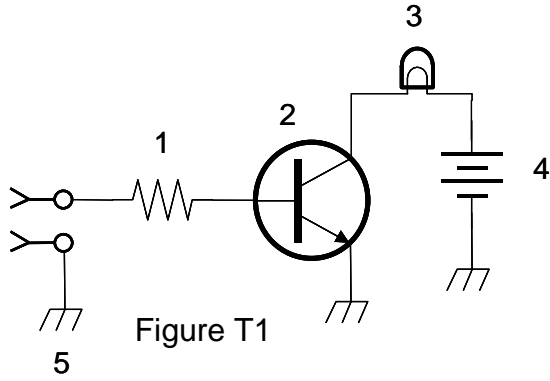

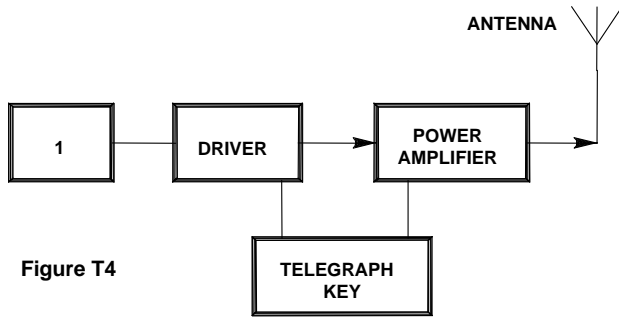

Figure T4

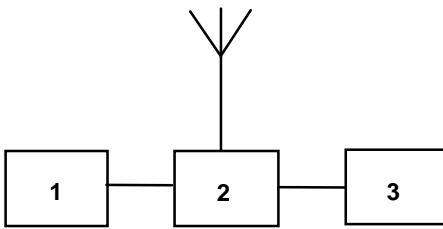

Figure T5

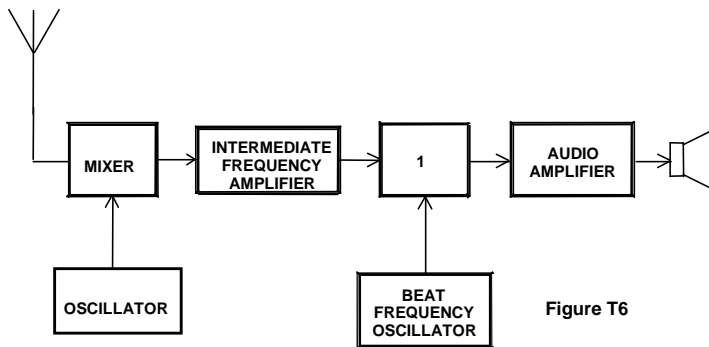

Figure T6